

Engine Oil

LUBRICATION

3. Engine Oil

A: INSPECTION

CAUTION:

If the engine oil is spilt over exhaust pipe or the under cover, wipe it off with cloth to avoid emission of smoke or causing a fire.

- 1) Park the vehicle on a level surface.
- 2) Remove the oil level gauge and wipe away the oil.
- 3) Reinsert the oil level gauge all the way. Be sure that the oil level gauge is correctly inserted and properly orientated.
- 4) Pull out the oil level gauge again, and check both sides of the oil level gauge. Use a lower side to determine the engine oil level. If the engine oil level is below "L" line, check for oil leakage from engine and add oil to bring the level up to "F" line.
- 5) Start the engine to circulate the oil in engine.
- 6) After turning off the engine, wait a few minutes for the oil to return to the oil pan before checking the level.

NOTE:

- To prevent overfilling of engine oil, do not add oil above "F" line when the engine is cold.
- As the oil level gauge is used for daily maintenance, "F" line and "L" line is set assuming that the engine is cold.

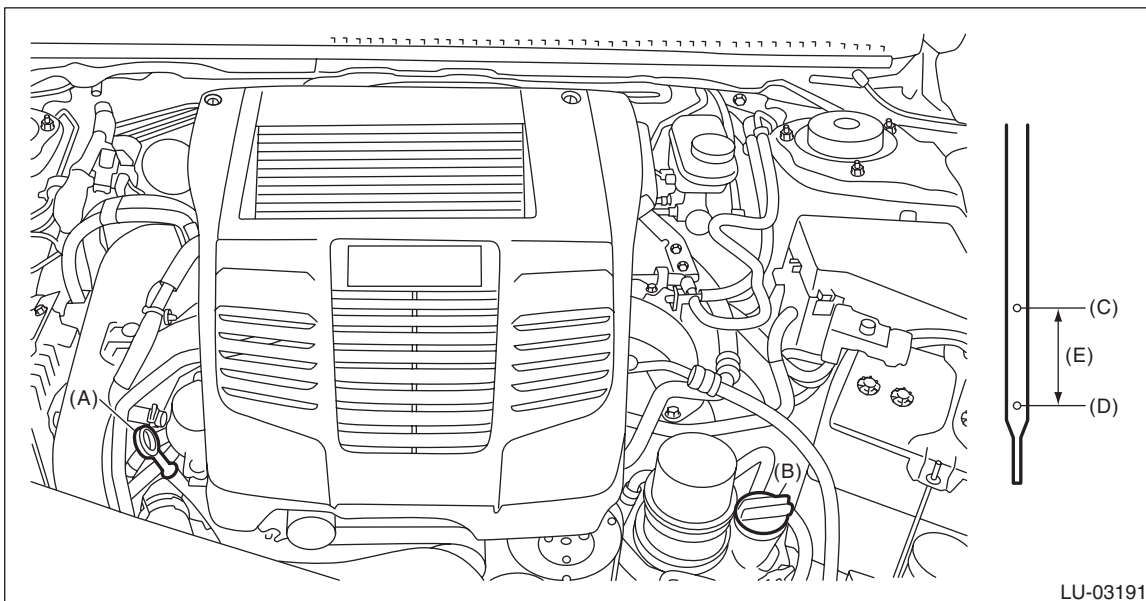

(A) Oil level gauge
(D) "L" line

(B) Oil filler cap
(E) Approx. 1.0 L (1.1 US qt, 0.9 Imp qt)

(C) "F" line

B: REPLACEMENT

CAUTION:

If the engine oil is spilt over exhaust pipe or the under cover, wipe it off with cloth to avoid emission of smoke or causing a fire.

- 1) Open the oil filler cap for quick draining of engine oil.
- 2) Lift up the vehicle.
- 3) Drain engine oil by loosening the drain plug.

NOTE:

Prepare the container for draining of engine oil.

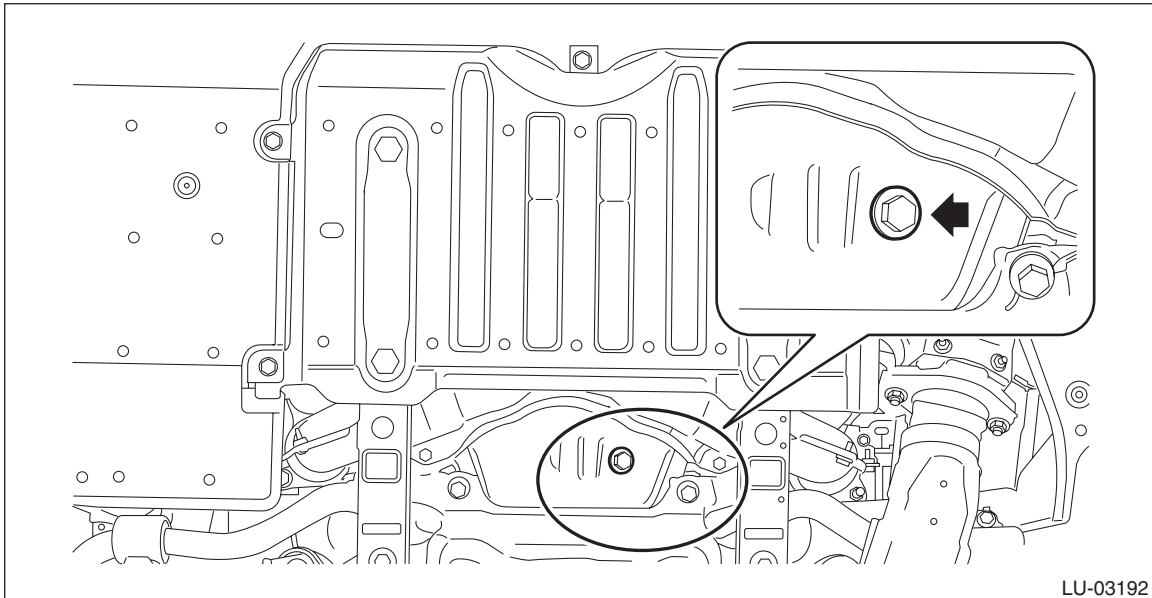

- 4) After draining the engine oil, tighten the engine oil drain plug.

NOTE:

Use a new drain plug gasket.

Tightening torque:

41.7 N·m (4.3 kgf·m, 30.8 ft·lb)

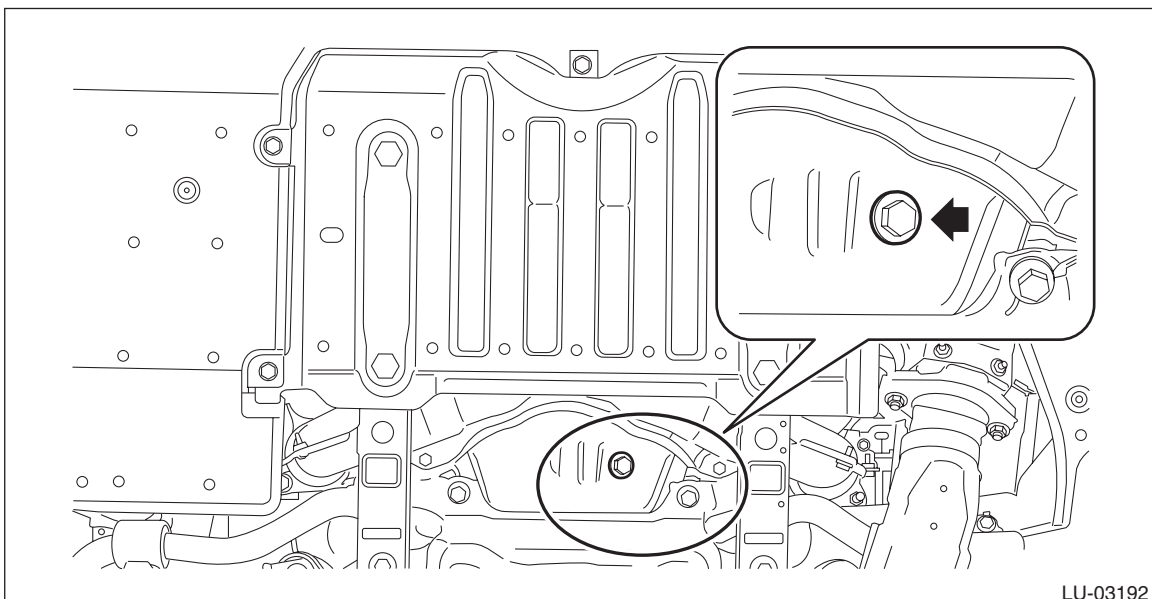

- 5) Lower the vehicle.

Engine Oil

LUBRICATION

6) Select engine oil of adequate quality and viscosity and fill it through the chain cover to the “F” line on the oil level gauge. Make sure that the vehicle is parked on a level surface when checking oil level.

Recommended oil:

Refer to “SPECIFICATION” for recommended oil. <Ref. to LU(w/o STI)-2, SPECIFICATION, General Description.>

Engine oil capacity:

Refer to “SPECIFICATION” for engine oil capacity. <Ref. to LU(w/o STI)-2, SPECIFICATION, General Description.>

7) Close the oil filler cap.

8) Start the engine to circulate the oil in engine.

9) Stop the engine and pull out the oil level gauge again, and check both sides of the oil level gauge. Use a lower side to check the engine oil level. If necessary, add engine oil up to the “F” line on oil level gauge.

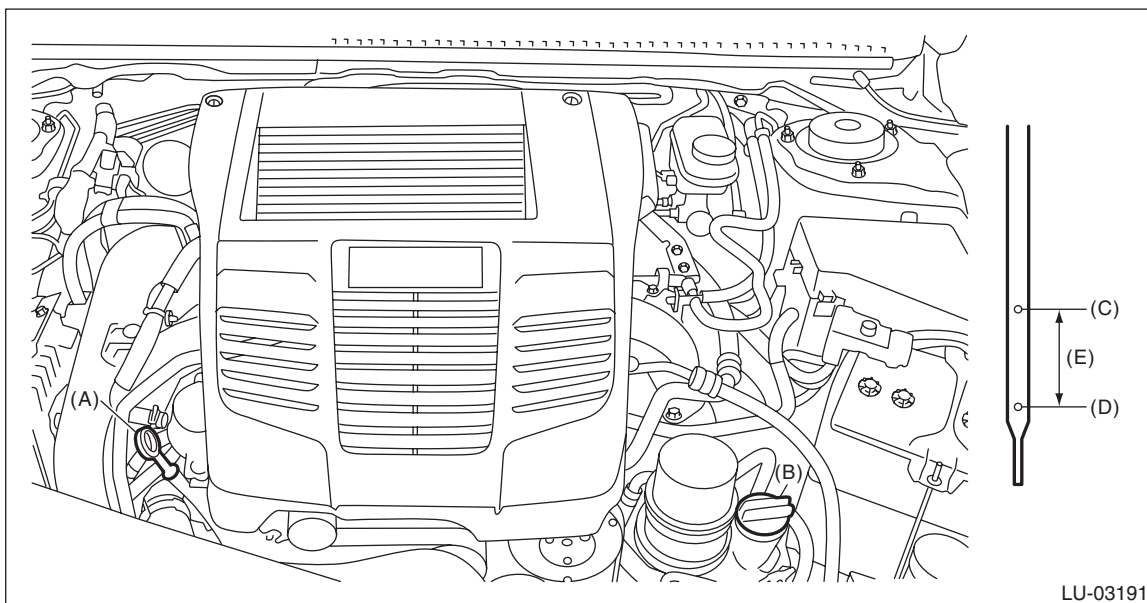

(A) Oil level gauge

(B) Oil filler cap

(C) “F” line

(D) “L” line

(E) Approx. 1.0 L (1.1 US qt, 0.9 Imp qt)